



XR-1000 HIGH PERFORMANCE DATA FOR CLOSED CIRCUIT RACING

General

This bulletin provides specification information and other data for improved performance of the XR-1000 motorcycle for closed circuit racing.

NOTE

Use of any of the Harley-Davidson part numbers listed in this bulletin voids all warranty.

Table of Contents

SUBJECT	PAGE
Engine	1-4
Transmission & Shifter	4-5
Clutch	6-8
Gearing	9
Ignition and Spark Plugs	9-10
Carburetion	11
Chassis 11	
Exhaust Pipes	11
Fuel and Oil	12
Suppliers	12

Engine

The stock XR-1000 engine will produce approximately 71 HP at 5600 RPM. In modified condition, with "E" cams, racing megaphones and high compression pistons installed, the engine will produce approximately 93 HP at 6400 RPM

Max RPM stock Engine	6200
Max. RPM Modified Engine	7200

HIGH COMPRESSION PISTONS

PART #	BORE	DISPLACE (cc)
		PER CYLINDER
22600-83R	Std.	499
22603-83R	+0.030	508
22605-83R	+0.060	518
22606-83R	+0.070	521

Piston to cylinder wall clearance: 0.0035 0.0045 in.

A break-in distance of 50 miles is required when new pistons are installed and cylinder is bored for 0.0035 clearance.

COMPRESSION RATIO

Do not exceed 10.5:1. The formula for calculating the compression ratio is:

$$CR = \frac{Vol.Cyl + Vol.Comb.Chamber}{Vol.Comb.Chamber}$$

To measure combustion chamber volume, do the followings

1. Coat cylinder wall with general-purpose grease. (This will prevent the oil, used to measure combustion chamber volume, from leaking past the upper piston ring.)
2. Install cylinder head and turn engine so piston is at top dead center (TDC) and both valves closed.
3. Tilt engine so spark plug hole is level.
4. Fill a beaker, having cubic centimeter (cc) graduations, with 75cc of light oil.
5. Place a small funnel in spark plug hole and fill combustion chamber with oil from the beaker. Continue filling until oil covers bottom two threads of spark plug hole.
6. Check the amount of oil remaining in beaker and subtract that amount from the original 75cc. The difference equals the combustion chamber volume-

EXAMPLE:

75cc Oil in beaker
 - 22cc Oil remaining in beaker
 53cc = Volume of combustion chamber

Insert the above volume and the cylinder volume given with high compression pistons into the compression ratio (CR) formula:

$$CR = \frac{499 + 53}{53} = \frac{552}{53} = \frac{10.4}{1}$$

$$CR = 10.4 : 1$$

INTAKE AND EXHAUST PORTS

Although the XR-1000 ports are very efficient, additional porting work can be done. Suppliers recommended are Branch Flowmetrics or C. R. Axtell. Supplier's addresses and phone numbers are listed on the last page of this bulletin.

FLYWHEELS

Before assembling the flywheel, extreme care must be taken in the cleaning of the tapers and the threads. After parts are cleaned in solvent it is necessary that the deposits are washed away with detergent and then rinsed in clean water. Clean tapers must not be touched with the fingers

FLYWHEELS AND SHAFTS

Torque to 120 ft-lbs. Leave them set overnight or a minimum of four (4) hours. (Use grease sparingly on the threads while keeping the tapers clean) When it is time to retorque, remove nuts, clean thread (see above), and add Loctite.

NOTE

If the procedures specify Loctite, use Loctite 620 RETAINING COMPOUND.

FLYWHEELS AND CRANKPIN

Torque to 100 ft-lbs and true assembly (Use grease sparingly on the threads while keeping the tapers clean.) Next torque to 175 ft – lbs, followed by the same waiting period and retorquing as for flywheels and shafts. Recheck runout.

NOTES

Loctite as well as grease serves as a lubricant during the tightening.

W-D 40 must not be used for lubricant as it will spread to the tapers.

Solvents leave a powdery deposit, which serves as a lubricant.

If time does not permit the retorquing procedure to be followed, all nuts should be assembled with Loctite immediately.

If Loctite /s used on tapers take care that none is spilled into the rod bearing (parts cannot be retorqued.)

Harley Davidson flywheels are made of cast iron. Forged steel flywheels are available from S & S Cycle

CAM SHAFTS

For best performance use Harley-Davidson "E" cams.

Order part number 25480-83R for a complete set of "E" cams.

"E" Cam Timing at 0.060 in. Tappet Lift is as follows:

Intake opens at	33° BTDC
Intake closes at	54° ABDC
Exhaust opens at	65° BBDC
Exhaust closes at	24° ATDC
Full tappet lift	0.300 in.
Rocker arm ratio	1.48
Valve Lash:	
"E" Cams with muffler	0.012 in.
"E" Cams with open megas	0.006 in.

CAUTION

Valve to valve clearance (valves on seat) should measure 0.180 in. minimum.

Be sure to check clearance between cam lobes and the crankcase (front intake and rear exhaust only).

See Figure 1 Install set screws in cam cover and cam bushing, as bushings may tend to work their way out.

Locate in bushing of number 1, 2, 3 and 4 camshaft and pinion shaft.

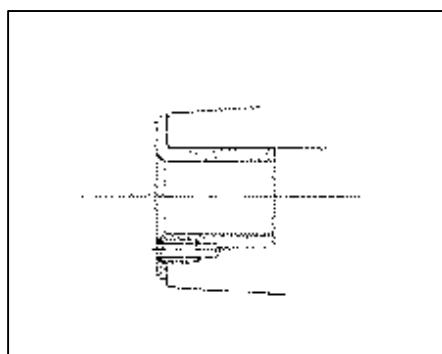

8-32 x 0.375 in. set screw

Figure 1. Retaining Cam Cover Bushings

CYLINDER STUDS AND NUTS

Be sure the cylinder head nuts are torqued to 30 ft-lbs.

CONNECTING RODS

Do not polish connecting rods, they are shot peened and polishing will destroy their properties.

PISTON RINGS

End gap top and second compression ring: 0.012-0.014 in.

Before installing the cylinders and pistons, make sure that the ring grooves for the compression rings, as well as the oil rings, are machined deep enough.

When rings are pushed against the bottom of the ring groove ring must be a minimum of 0.015 in. below outside diameter of the piston.

OILING SYSTEM See Figure 2 Add baffle plate to crankcase sump as shown.

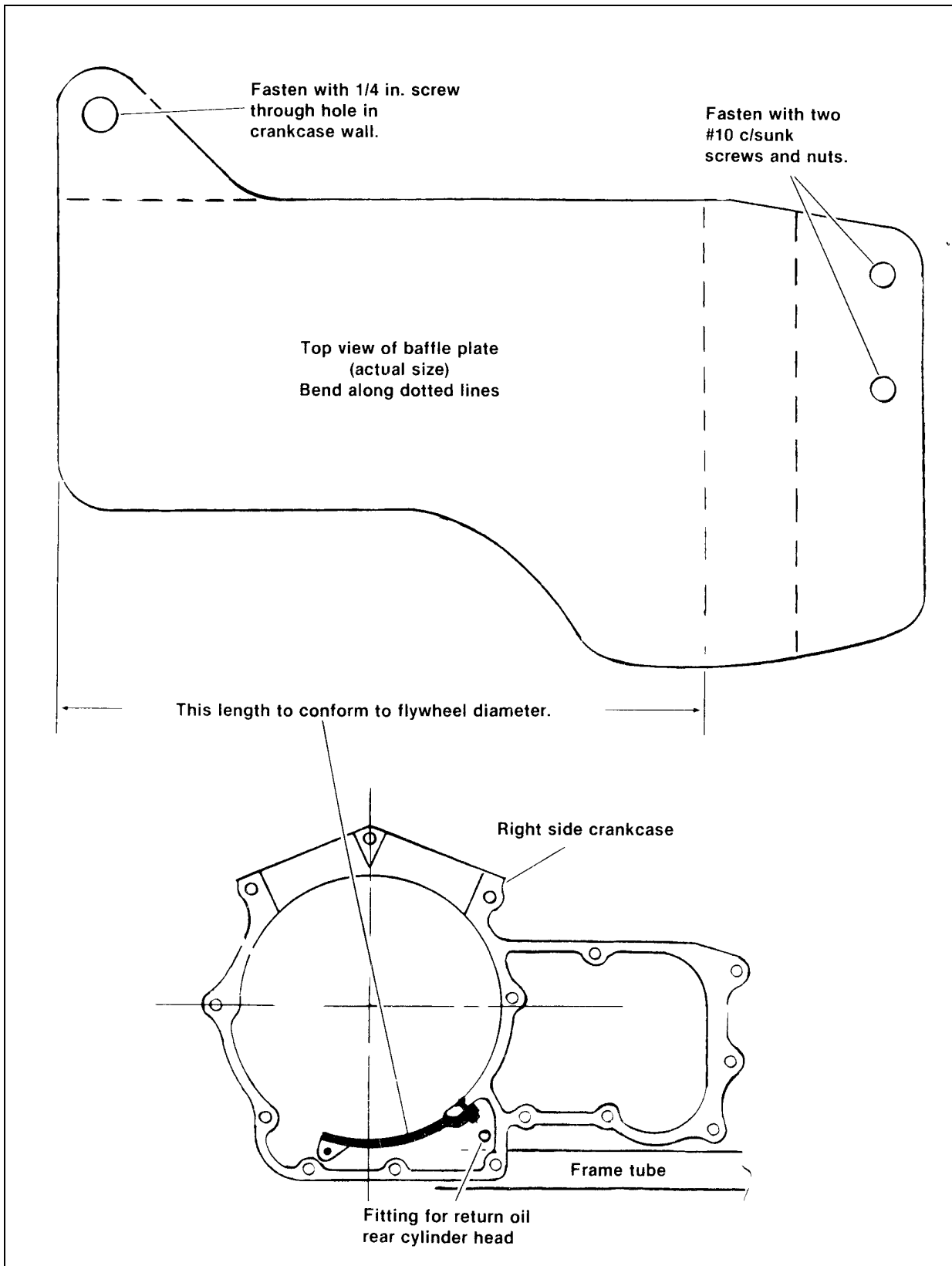

Figure 2. Oil System Modifications

Change return oil line from rear cylinder head to drain directly into sump For this a 1/8 in. taper pipe thread hose fitting has to be installed in the right crankcase (see bottom view of Figure 2). Locate this fitting with engine mounted in the frame.

Proper placement will be above the lower frame tube and behind the vertical crankcase boss for oil pick-up hole.

To reduce oil flow to the connecting rod bearing a restrictor should be pressed into the pinion shaft One way to make this would be to machine the thread off a carburetor main jet (A main jet from an MX, SS or SX carburetor may have the following dimensions.)

- Pinion shaft hole size 0.19 ± 0.02 in.
- Restrictor hole size 0.090 in.

CYLINDER BASE GASKET

Eliminate the gasket use Dow Corning 732 silicone sealant.

Transmission

In road racing 1st 2nd and 3rd gears are used more frequently than in normal street use The bushing in the clutch gear is subjected to higher speeds and must be packed in grease or in its place a needle bearing (Torrington #B1010) can be installed. See Figure 3. To allow use of the needle bearing the mainshaft must be ground to dimensions shown Remove stock bushing and press needle bearing into clutch gear as shown.

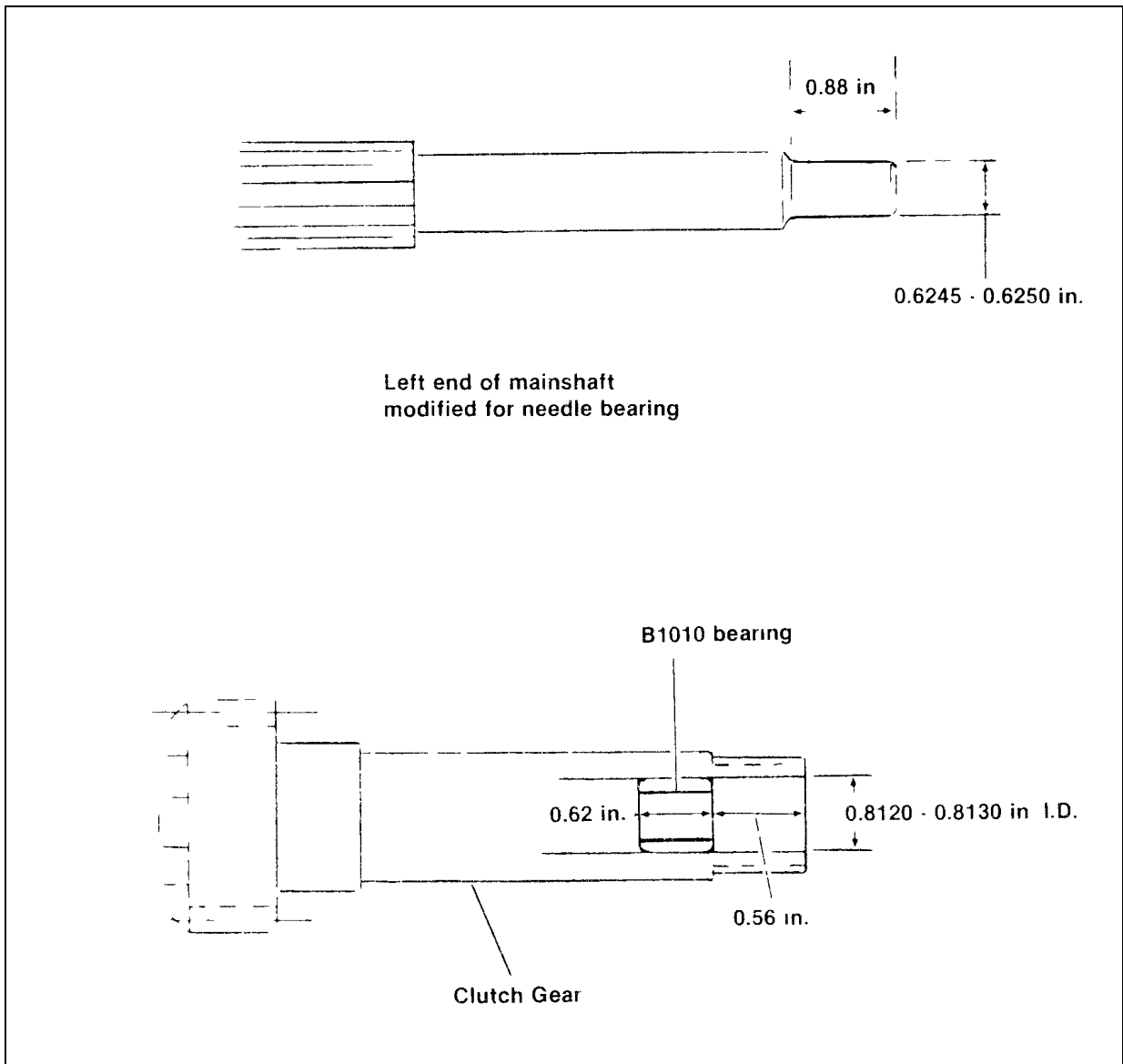

Figure 3. Transmission Modification

SHIFTER MECHANISM

The shifter forks are subjected to heavy loads. This can be reduced by carefully modifying the shifter cam plate. See Figure 4. The removal of metal at the shaded areas of cam plate will allow more engagement of the gears. In order to find out where and how much material has to be removed, put transmission in each of the four gears and recheck for each gear, what is required to make the gears engage more completely. Figure 4 shows where metal must be removed, if necessary.

Remove a little metal at a time and recheck engagement of gears. Repeat until gears are fully engaged with one another.

Shifter forks should be free while holding gears together.

Shifter cam grooves and outside surface where plunger rides, should be polished for smoother operation.

Remove countershaft oiler plug on transmission door to eliminate the chance of it coming out.

A close ratio 3rd gear ("C" ratio) is available from Andrews Products.

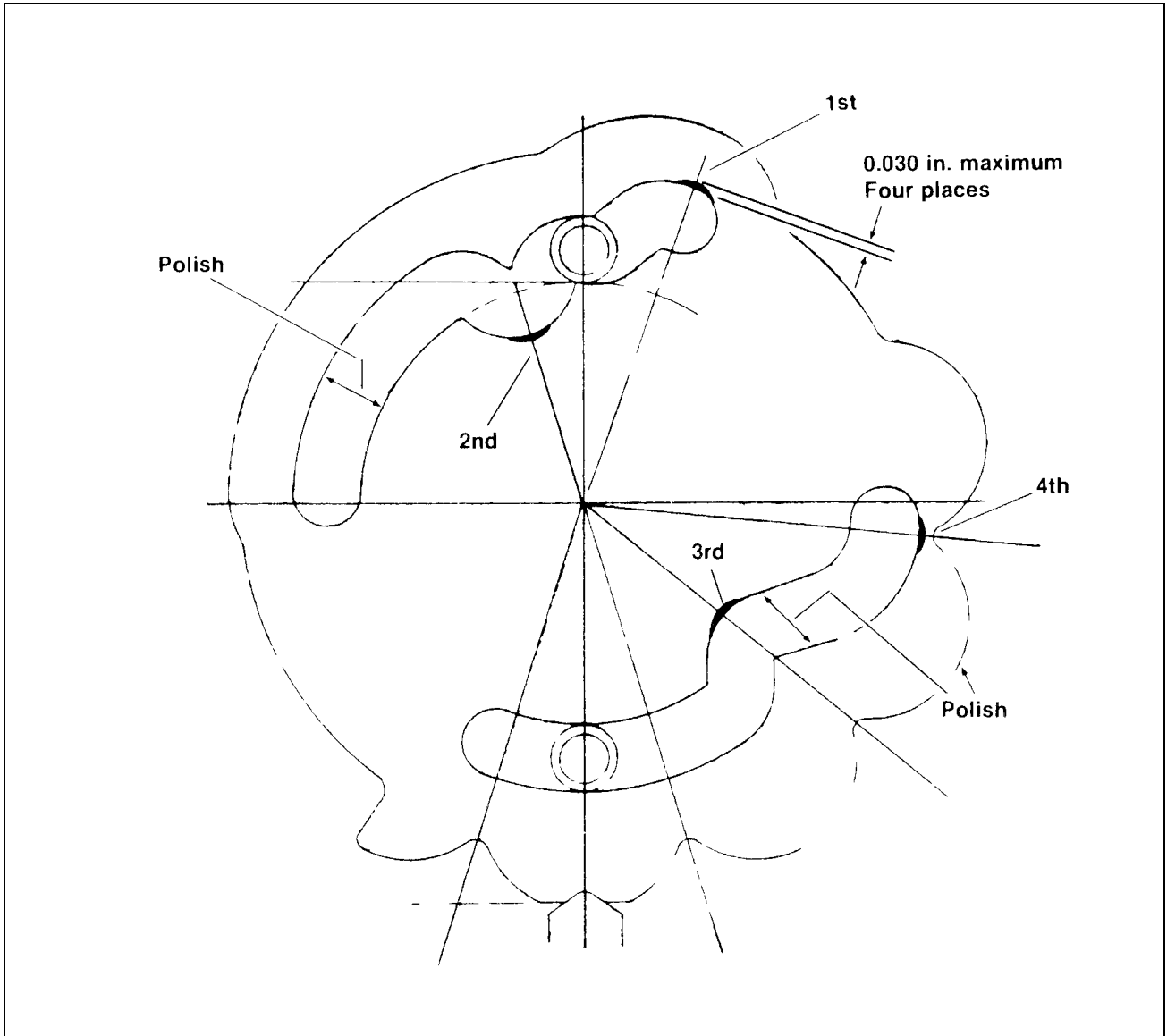

Figure 4. Shifter Plate Modification

Clutch Modifications

To improve operation of the clutch, more oil must be allowed to flow through. The following operations are recommended.

CLUTCH SHELL

See Figure 5. To sling oil out of the clutch, drill two 0.19 in. diameter evenly spaced holes in each driving groove (24 holes total). Drill three 0.38 in. diameter equally spaced holes in back plate.

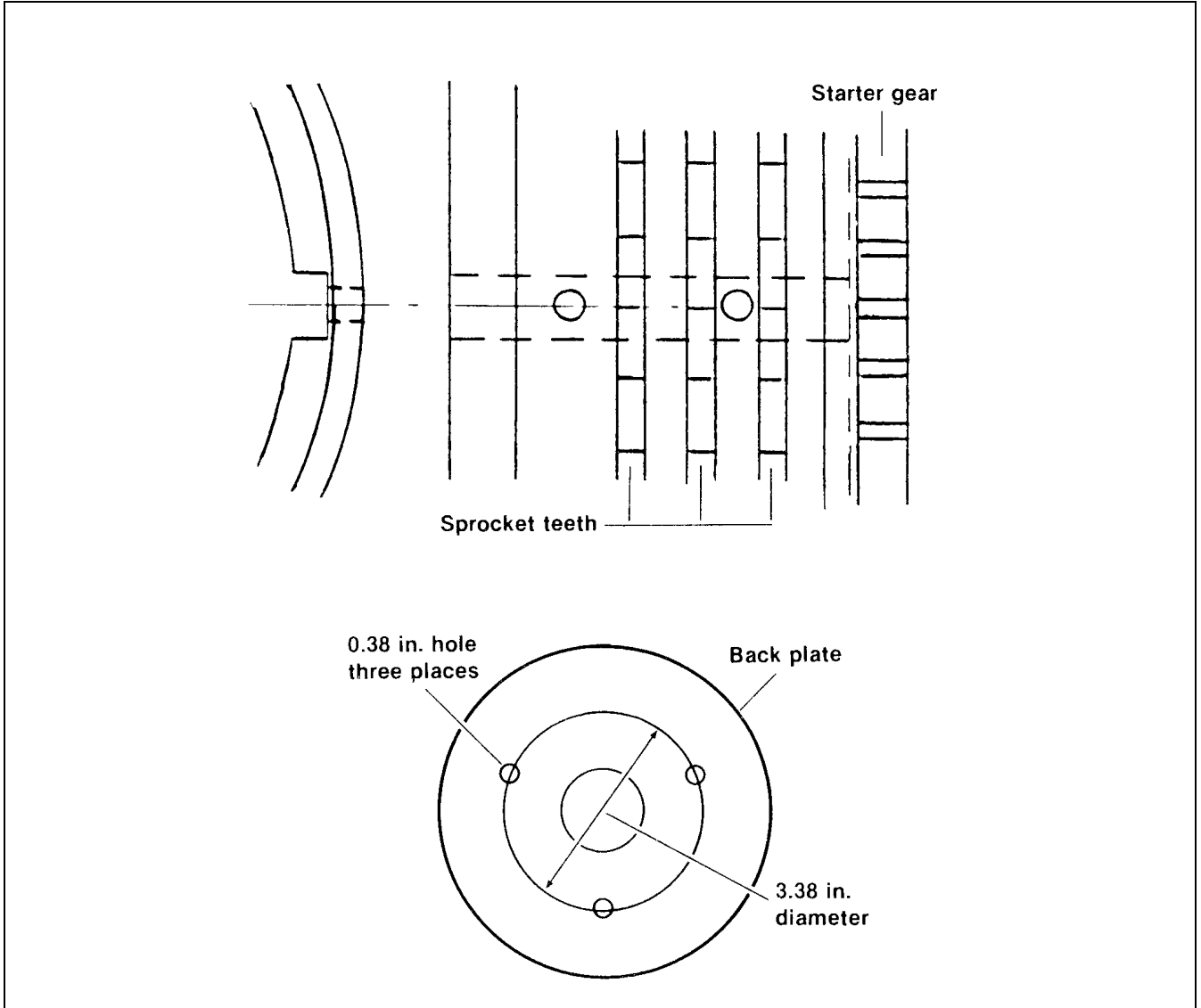

Figure 5. Clutch Shell Holes

CLUTCH HUB

See Figure 6. Drill a diagonal pattern of six 0.09 in. diameter holes all around hub while taking care that the

no. 3 and no. 5 holes do not run out into hub center plate. Seven 0.25 in. diameter holes must be drilled flush with inside diameter (I.D.) of hub rim (where no. 4 holes break through).

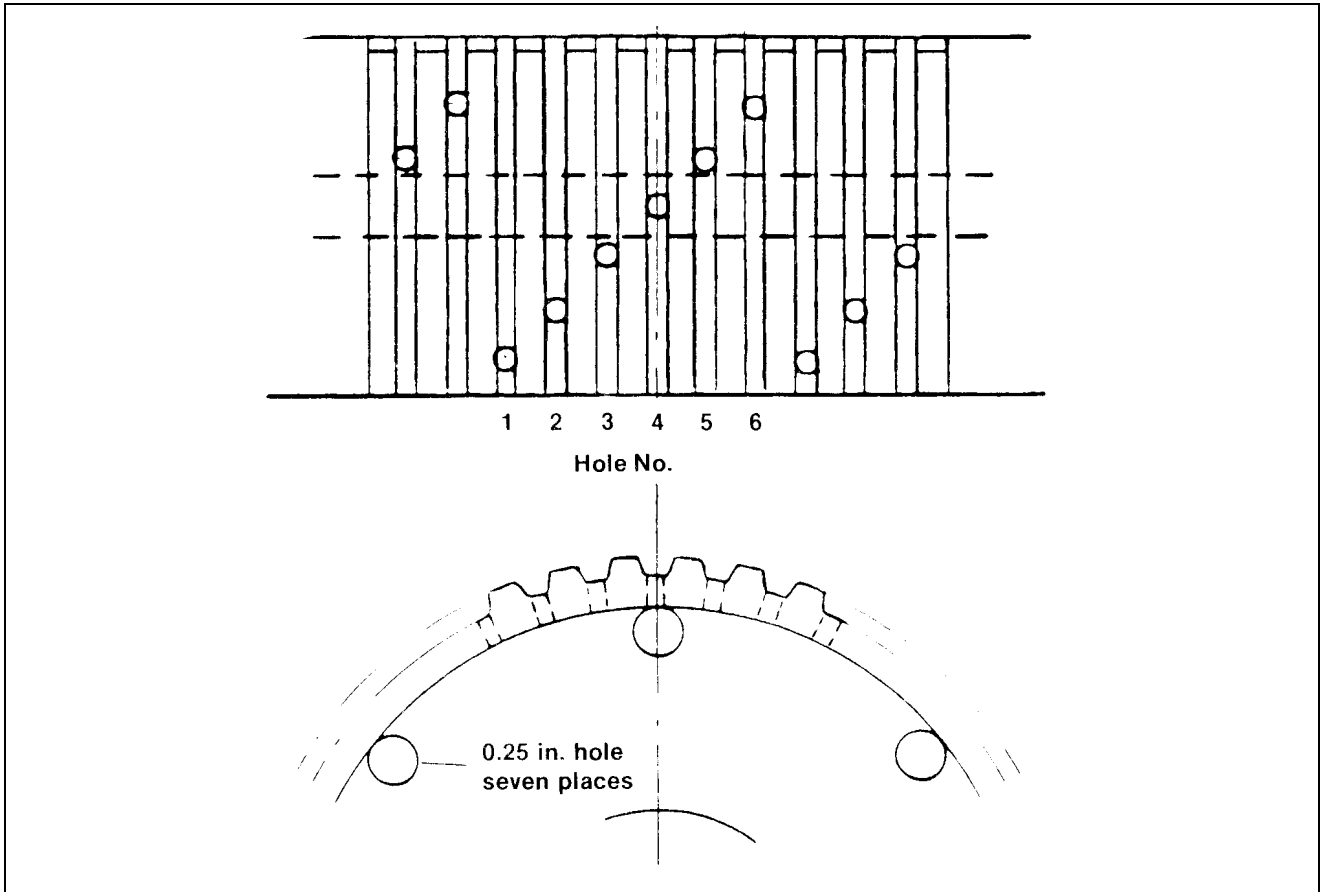

Figure 6. Clutch Hub Holes

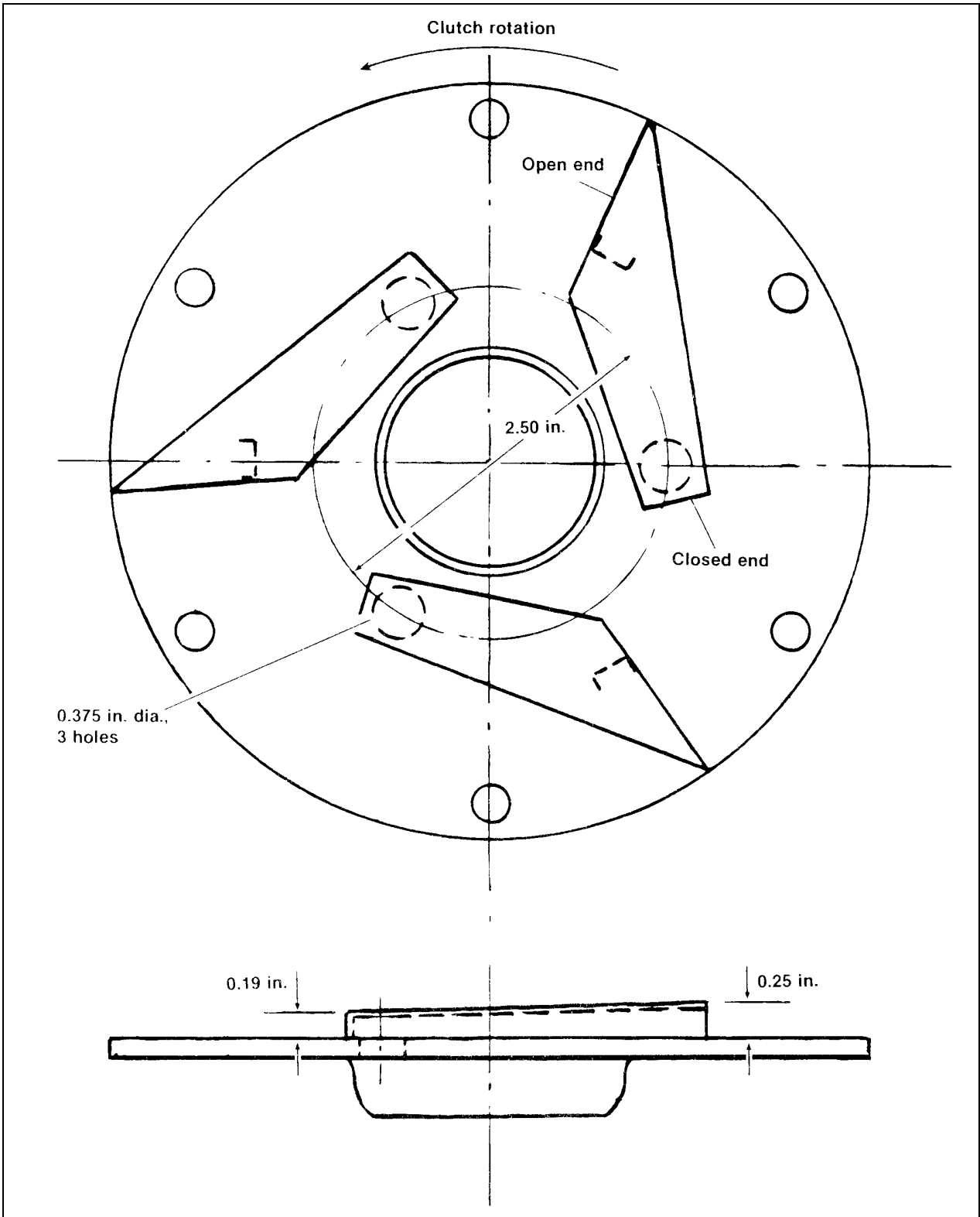

Figure 7. Clutch Release Disc Modification

Modification, Clutch Release Disc

See figure 7. In order to circulate more oil through the clutch, three scoops must be added to the clutch release disc.

Fabricate the scoops from light gauge steel sheet metal. Drill three 0.375 in holes through the clutch release disc. Position the scoops and weld them in place.

Overall Gear Ratios

The overall gear ratios with various sprockets are listed in the following chart.

REAR WHEEL SPROCKET (TEETH)	TRANSMISSION SPROCKET (TEETH)		
	19	20	21
	Overall Gear Ratios		
40	3.65	3.47	3.31
41	3.74	3.56	3.39
42	3.84	3.64	3.47
43	3.93	3.73	3.55
44	4.02	3.82	3.64
45	4.11	3.90	3.72
46	4.20	3.99	3.80

NOTE

Transmission sprockets with 19 and 20 teeth require a 0.090 in. thick spacer.

PART

HARLEY-DAVIDSON PART NUMBER

19 T Transmission Sprocket	35197-52
20 T Transmission Sprocket	35198-52
21 T Transmission Sprocket	35205-52A

Speed Formula

$$\text{Miles / Hour} = \frac{S * C}{1056 * R}$$

S = Engine RPM

C = Tire circumference (inches)

R = Overall Gear Ratio

Average gearing for Stock bikes 3.84

Ignition Timing

For Stock and Modified classes full advance ignition timing is 30° BTDC above 2000 RPM.

Spark Plugs and Cables

If stock Magnavox ignition is used also use resistor spark plugs and stock carbon core spark plug cables. This will prevent problems with electronic ignition module and tachometer.

Champion resistor spark plugs are identified by the letter R in front of spark plug type ie. RN6YC.

Spark plug gap should be closed up to 0.022 in (Stock and Modified classes).

Since the heat range required for each cylinder may not be the same it is necessary to take plug readings on both cylinders. See spark plug chart for heat ranges.

HEAT RANGE	PROJECTED	PROJECTED	REGULAR	FINE WIRE	RETRACTED			
HOT	RN7YC	N7YC	N4C					
	RN6YC	N6YC	N3C	N87				
		N4YC	N2C	N86	N62R	G63R	HEAT RANGE STOCK & MOD.	
	N60		N84	N60R	G61R			
COLD			N57	N82	N57R	G59R		
						G58R		
					14 mm	10 mm		

RACING HEAT RANGE CHART FOR CHAMPION SPARK PLUGS

See Figure 8. The engine will run cooler with an additional spark plug installed on the right side of the cylinder head. With two (2) plugs installed, make the following changes:

*See spark plug chart for recommended 10 mm plugs.

Ignition Timing	17-20° BTDC
Gap 14 mm Plug	0.018 in.
Gap 10mm Plug*	0.015 in.

Connect two coils in parallel to make all plugs fire at the same time.

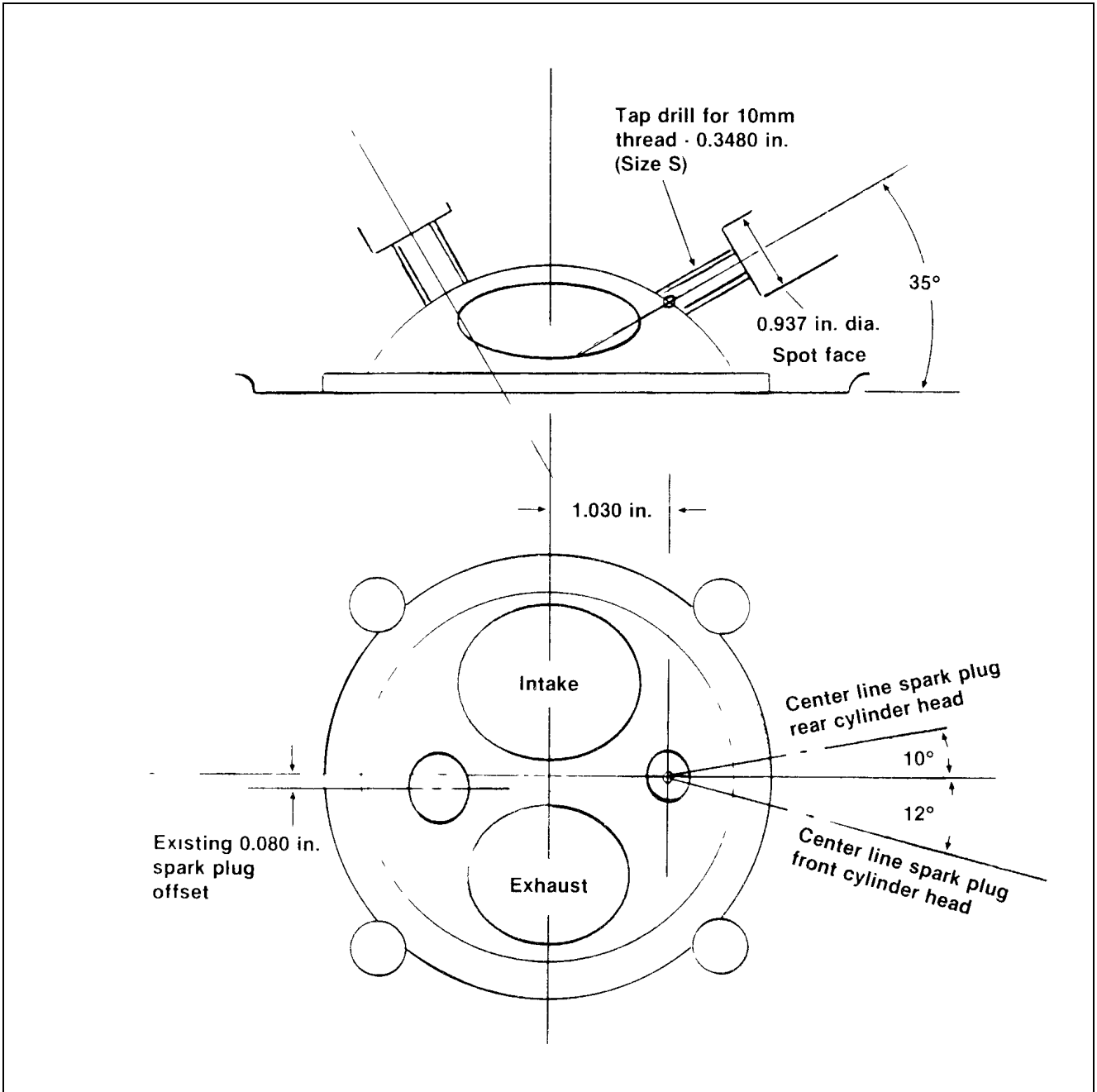

Figure 8. Installing Additional Spark Plug

Carburetion

For best results jet both carburetors individually.

The accelerator pump should be disconnected by removing the plastic lever (cam follower) from the carburetor cover.

If stock mufflers are replaced by megaphones the main jets have to be increased by approximately two sizes.

D'Ellorto	36 mm	40 mm
Main Jet	140-155	145-160
Slide	50/3	60/5
Needle	K27	K4
Needle Jet	262AB	265AB
Idle Jet	62-65	62-65

Suppliers for D'Ellorto carbs and parts is Cosmopolitan Motors.

Forty-one mm Lectron carburetors and tapered manifolds are available from Branch Flowmetrics.

Specially modified flat slide Mikuni carburetors are available from Storz Performance.

Chassis

Front fork: Use 20W fork oil. To check oil level in fork legs, remove springs and bottom out the suspension. The distance from the top of the fork to the oil level should be 5.8 in. with the suspension bottomed out. Be sure spring is free from oil at the time of installation.

See figure 9. To increase compression damping, one of the two 0.24 in. diameter holes in the fork damper tube has to be

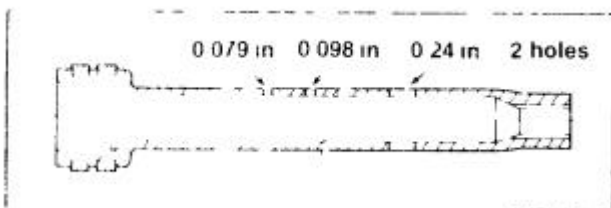

plugged.

Figure 9 Fork Damper Tube Modification

REAR SHOCKS

The following shocks and springs are recommended:

Shock: Koni #7610F-1283 (13½ in. lg.)

Spring: Koni #250-15-21-28

Supplier - Parts Unlimited

KICK STAND

The kick stand must be removed.

THROTTLE

The throttle should be lubricated with Bel Ray 6 in 1 oil. Do not use dry slide lubricant.

FUEL VALVE

Remove stand pipe in fuel valve and turn knob to reserve for maximum fuel flow.

IGNITION SWITCH

Pack wire on the back of switch in RTV silicon sealant to prevent it from breaking.

REAR SET FOOTRESTS

Raise master cylinder 2½ in. and turn brake and shifter levers around.

For the new location of the footrests use a rear footrest support from a 1982 XL.

PART	HARLEY-DAVIDSON PART NUMBER
Footrest Support (1)	52706-82
Footrest (2)	33048-72
Locknut (2)	7778
Bolt (2)	4721

A rear swingarm mounted footrest kit is available for the XL models and can also be used for the XR-1000. Order Harley-Davidson Part No. 49105-83.

HANDLEBARS, STOCK CLASS ONLY

Upside down mounted handlebars from a 1983 XLS, or Harley-Davidson Dragbike handlebars work very well. If the dragbike bars are used, a notch must be made in the switch housing to prevent the wires from being cut.

PART	HARLEY-DAVIDSON PART NUMBER
XLS Handlebar	56082-83
Dragbike Handlebar	55963-77

REAR FENDER

Flatten rivets on bottom side of rear fender to prevent interference with tire.

Exhaust Pipes

The Harley-Davidson part number for the exhaust pipe kit is 80078-83.

To prevent cracking exhaust pipes must be mounted without stress.

Modified class: Springs can be used to mount header pipes and hold joints together. Interconnector can have slip fit.

Fuel

Stock Class: The use of racing gasoline is recommended. However, a premium leaded or unleaded gasoline with a minimum octane rating of 92 is satisfactory.

Modified Class: Use racing gasoline only.

Oil

Engine:

HD20W50 Power Blend. (Mineral Oil)
40W Racing Oil (Mineral Oil)
40W Castor Oil (Vegetable Oil)

Transmission: Racing automatic transmission fluid
(available at automotive performance shops).

OIL FILTER

The oil filter must be safety wired. A hose clamp secured to the outside of the filter provides a means for safety wiring the filter.

Suppliers

Andrews Products
5212 North Shapland Avenue Rosemont, IL 60018
312-992-4014

Branch Flowmetrics
5556 Corporate Drive Cypress, CA 90623
714-827-1463

C. R. Axtell
10949 Tuxford Street, #17
Sun Valley, CA 91352
213-768-5594

Cosmopolitan Motors
Jacksonville & Meadowbrook Roads
Hatboro, PA 19040
215-672-9100

Parts Unlimited
P. O. Box 9238
Asheville, NC 28805

S & S Cycle
Route 2, County G
Viola, WI 54664
608-627-1497
Storz Performance
1362 Tower Square, #2
Ventura, CA 93003
805-654-8816